

Domestic Residential Range

WATER VERSION

TEON Domestic Residential range in **Water** version (water-water) consists of water-water monobloc natural heat generators, for the production of heating and domestic hot water (DHW), having the option of reversibility for the summer cooling operation.

T10 and **T30** models are single-stage, capable of delivering:

- high temperature hot water (min 30°C – max 80°C);
- chilled water at low temperature (min 5°C) – only in the “**RT**” models.

The compressors used are of alternative type with high energy efficiency. They are developed and optimized for applications with R600a refrigerant, they minimize electrical absorption, vibrations and noise.

The heat exchangers are made of 316 AISI stainless steel plates, brazed, with counter-current heat exchange and AISI 304 stainless steel connections. They are characterized by high thermal efficiency with at the same time strong turbulence and lower risk of formation of fouling and deposits. Inside the supporting structure with perimeter paneling, the main components of the machine are placed. Inside the supporting structure with perimeter paneling, the main components of the machine are placed:

- Compressor
- Expansion valve
- Evaporator
- Condenser
- Economizer
- Measurement and control components
- Piping and various components online
- Machine edge



**WATER
BLAZE**[®]
TECHNOLOGY

TEON's WATER BLAZE technology introduces a pushed sub-cooling into the traditional thermodynamic cycle of heat pumps, thanks to which more thermal power is recovered from the natural source to be transferred to the heating system. This results in the overall efficiency maximization. This is done by splitting the isoenthalpic curve into two distinct transformations, one at constant pressure and one at constant temperature, which take place in a recuperator and in a lamination valve respectively

TECHNICAL DATA

PERFORMANCE	U.M.	T10			T30		
HEATING (T models)							
Thermal Power	[kW]	12,1	11,8	9,8	34,7	33,4	27,3
Electric Power	[kW]	1,9	2,8	3,3	5,7	7,9	8,8
COP	[-]	6,38	4,27	3,00	6,09	4,22	3,12
Inlet water temperature from source	[°C]	10	15	15	10	15	15
Outlet water temperature to source	[°C]	7	10	10	7	10	10
Inlet water temperature from plant	[°C]	30	50	70	30	50	70
Outlet water temperature to plant	[°C]	35	60	80	35	60	80
Water flow on the source side	[l/s]	0,81	0,43	0,31	2,31	1,22	0,89
Water flow on the plant side	[l/s]	0,58	0,28	0,23	1,66	0,80	0,65
Refrigerant charge (R600a)	[kg]		0,9			2,5	
COOLING (RT models)							
Refrigeration Power	[kW]		9,7			28,4	
Electric Power	[kW]		1,9			5,7	
EER	[-]		5,15			4,99	
Outlet water temperature to source	[°C]		20			20	
Inlet water temperature from source	[°C]		15			15	
Outlet water temperature to plant	[°C]		7			7	
Inlet water temperature from plant	[°C]		12			12	
Water flow on the source side	[l/s]		0,55			1,63	
Water flow on the plant side	[l/s]		0,46			1,36	
Refrigerant charge (R600a)	[kg]		1,2			3,1	

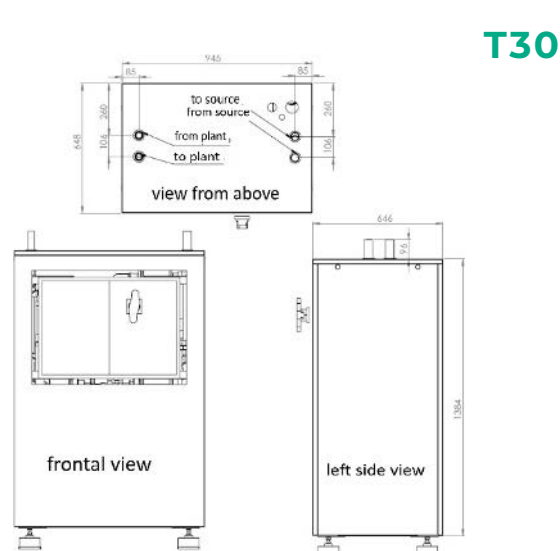
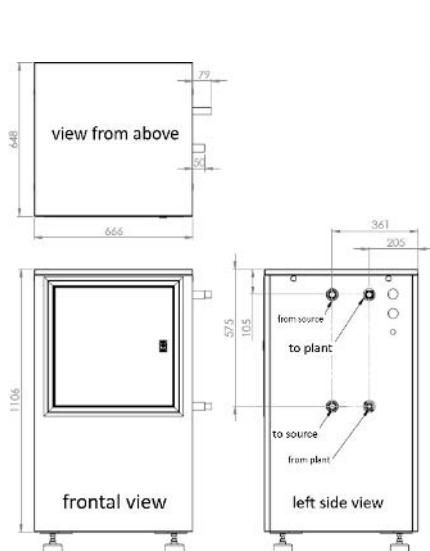

NOTE: For both **T10** and **T30**, the following clearances apply: front and rear 500 mm, side left and right 600 mm and top 500 mm.

TECHNICAL DATA	U.M.	T10	T30
Max nominal electric current	[A]	6,2	15,3
Sound pressure level 1 m (*) (w.o. Acoustic Insulation optional)	[dB(A)]	55	58
Sound pressure level 5 m (*) (w.o. Acoustic Insulation optional)	[dB(A)]	41	44
Sound pressure level 10 m (*) (w.o. Acoustic Insulation optional)	[dB(A)]	35	38
Water circuit load loss on evaporator side	[kPa]	12	10
Water circuit load loss on condenser side	[kPa]	20	48
Power supply	[V/-/Hz]	400/3/50+N (220 V)	400/3/50+N (220 V)
Compressors type	[-]	Alternativo	Alternativo
Partialization (with partialization optional)	[-]	-	75
SIZES AND WEIGHTS	U.M.	T10	T30
Dimensions (L x P x H) (**)	[mm]	666 x 648 x 1106	945 x 648 x 1384
Empty weight	[kg]	280	460
Operating weight	[kg]	300	500
Diameter source side hydraulic connections (T and RT)	[-]	G 1"	G 1 1/4"
Diameter plant side hydraulic connections (T)	[-]	G 3/4"	G 1"
Diameter plant side hydraulic connections (RT)	[-]	G 1"	G 1 1/4"
SAFETY	U.M.	T10	T30
Maximum pressure of the refrigerant	[bar]	14	14
F-GAS license need for maintenance	[-]	NO	NO

(*) The data reported are from free-field measurements.

(**) The quoted height does not take into account the anti-vibration mounts, which would increase the total height by between 60 mm and 110 mm.